



Desde 1928

Petersen

P6

**SOLAR SCREEN
SOLAR CONTROL**
SMART SOLAR SOLUTIONS

Protects from UV, heat
and excessive glare

P20

**SOLAR SCREEN
SAFETY**
SMART SECURE SOLUTIONS

Reinforces windows
against glass breakage

P32

**SOLAR SCREEN
AUTOMOTIVE**
SMART TINTING SOLUTIONS

Improves the comfort
and aesthetic of the
vehicle

P42

**SOLAR SCREEN
PRINTING**
SMART GRAPHIC SOLUTIONS

Customizes your windows
with your ideas



A WHOLE WORLD OF SOLUTIONS

P48

**SOLAR SCREEN
DESIGN**
SMART VISUAL SOLUTIONS

Dresses up and privatizes
your windows regarding
your tastes

P54

**SOLAR SCREEN
ADVANCED**
SMART INNOVATIVE SOLUTIONS

The future of films on your glass

P64

**SOLAR SCREEN
STORE D'INTERIEUR**
SMART BLIND SOLUTIONS

Tailor-made Stores d'interior

P70

**SOLAR SCREEN
COVER STYL'**
SMART INTERIOR DESIGN

Why replace when you can
upgrade?



OUR DNA

YOU ARE UNIQUE



SO IS THE SERVICE YOU DESERVE FROM US!

A sales relation with us :

- ✓ Dedicated contact person
- ✓ In your language
- ✓ Going the extra mile
- ✓ Flexible for your business needs
- ✓ Human, dynamic & fun
- ✓ Since '84

YOUR NEEDS, SIMPLY DELIVERED



OUR DAILY COMMITMENT

At Solar Screen you can count on

- ✓ Wide range of products
- ✓ In stock
- ✓ At a competitive price
- ✓ Without MOQ
- ✓ Shipped on the day of order
- ✓ Controlled CO2 footprint

YOUR GROWTH, OUR DRIVE



LONG-TERM, THE ONLY WAY WE SEE OUR RELATION!

Multiple solutions

- ✓ Building product awareness
- ✓ Strong technical expertise
- ✓ In-house trainings
- ✓ Customized marketing for your brand
- ✓ New products through R&D
- ✓ Investing for you

+4 MILLIONS M²
FILM YEARLY

+1000
REFERENCES

+35 YEARS
OF EXPERIENCE

+65 000
ROLLS IN STOCK



ONE MORE STEP TOWARDS SUSTAINABLE DEVELOPMENT

Solar Screen is now certified as a CO2-neutral inbound logistics company. 100% of the CO2 emitted by the inbound transport is now compensated: a compensation of 1.1151 tons of CO2 for 2019.





HOW DOES IT WORK?

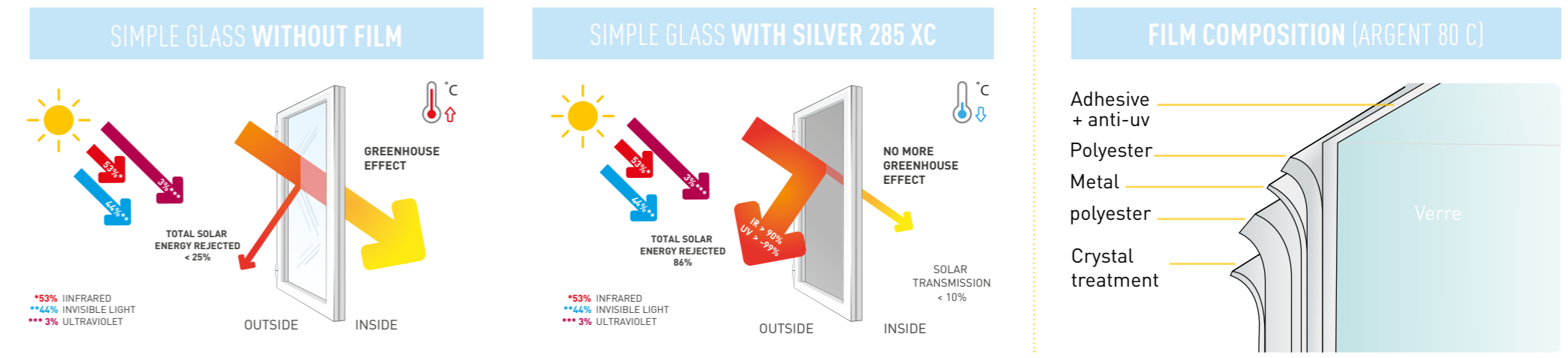

3 CRITERIAS FOR THE SOLAR FILMS:



TOTAL SOLAR ENERGY REJECTED

The higher it is, the lower the total heat and cooling savings are realized.

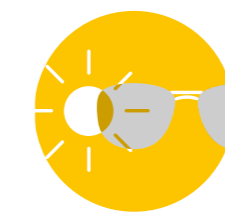

GLARE REDUCTION

The higher it is, the better the visibility on your screens.



LIGHT TRANSMISSION

The higher it is, the higher the brightness.

→ **Visual acuity** has to be taken into account

The **excessive heat** on your glass surfaces exposed to the rays of the sun is a recurring problem and difficult to fight without significantly increasing its air conditioning invoice. It also causes a decrease of the concentration and therefore the productivity.

We offer adapted **solutions** to this problem with our Silver ranges, the most used.

SOLUTIONS

HEAT PROBLEM?



THE CHROME RANGE

This film is applied to the outside of all types of glass to form a reflective screen that reflects solar energy, with 3 shades of tint depending on performance. It is also the most advanced range of film, offering up to 10 years warranty.

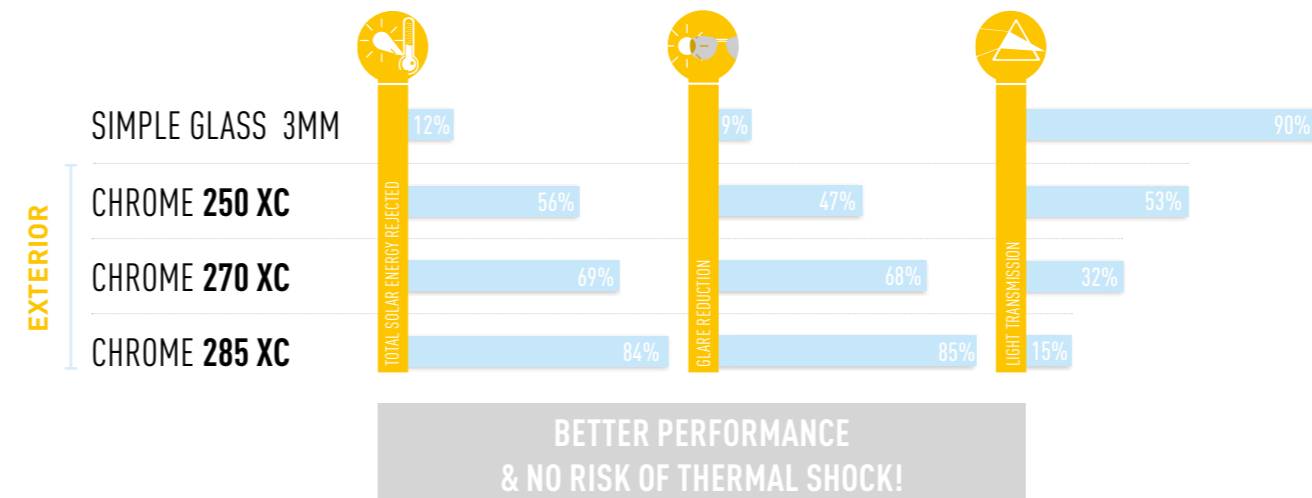

THE SILVER RANGE

This film is applied on the outside of any type of glazing to form a reflective screen that reflects solar energy.

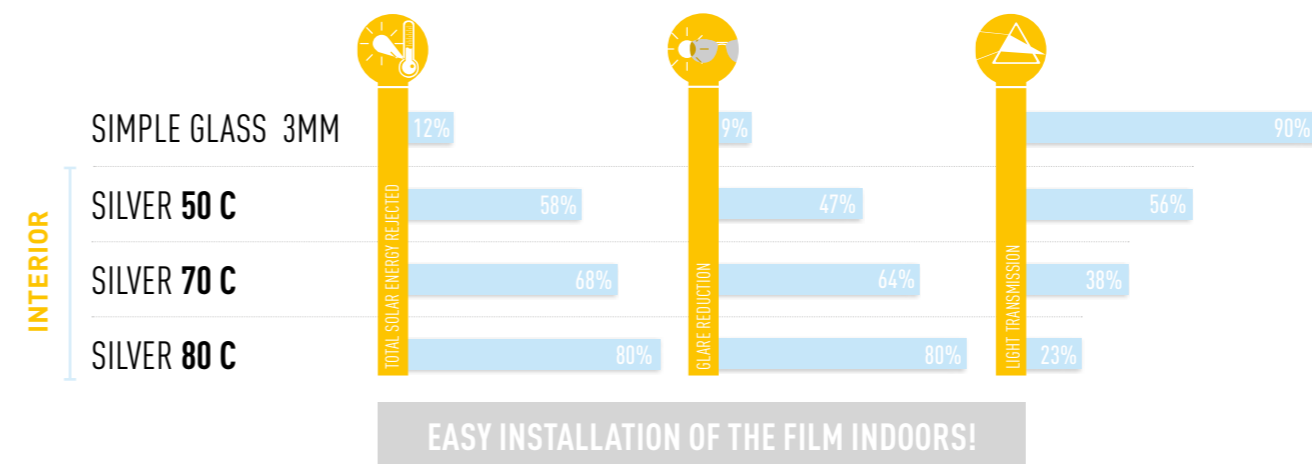

CHROME 285 XC

Valencia Airport - Spain



DISCOVER
our installation video
on our **YouTube** channel!
> Solar Screen International

- > Reduction of the greenhouse effect and therefore of the internal heat
- > Intimacy and glare reduction via mirror effect depending on the chosen metallization density
- > 99% UV absorption
- > Longevity of Chrome films, latest generation Outdoor
- > Energy savings (air conditioning), which can pay for itself in just 4 years (Chrome 285XC)

The **excessive heat** caused by the sun tapping windows is a recurring problem that is difficult to combat without darkening the interior.

We offer **solutions** for a good compromise with our Spectra range.



NEED TO REDUCE HEAT WITHOUT LOOSING BRIGHTNESS?

THE SPECTRA RANGE

This film forms an almost transparent infrared barrier that reduces solar energy.

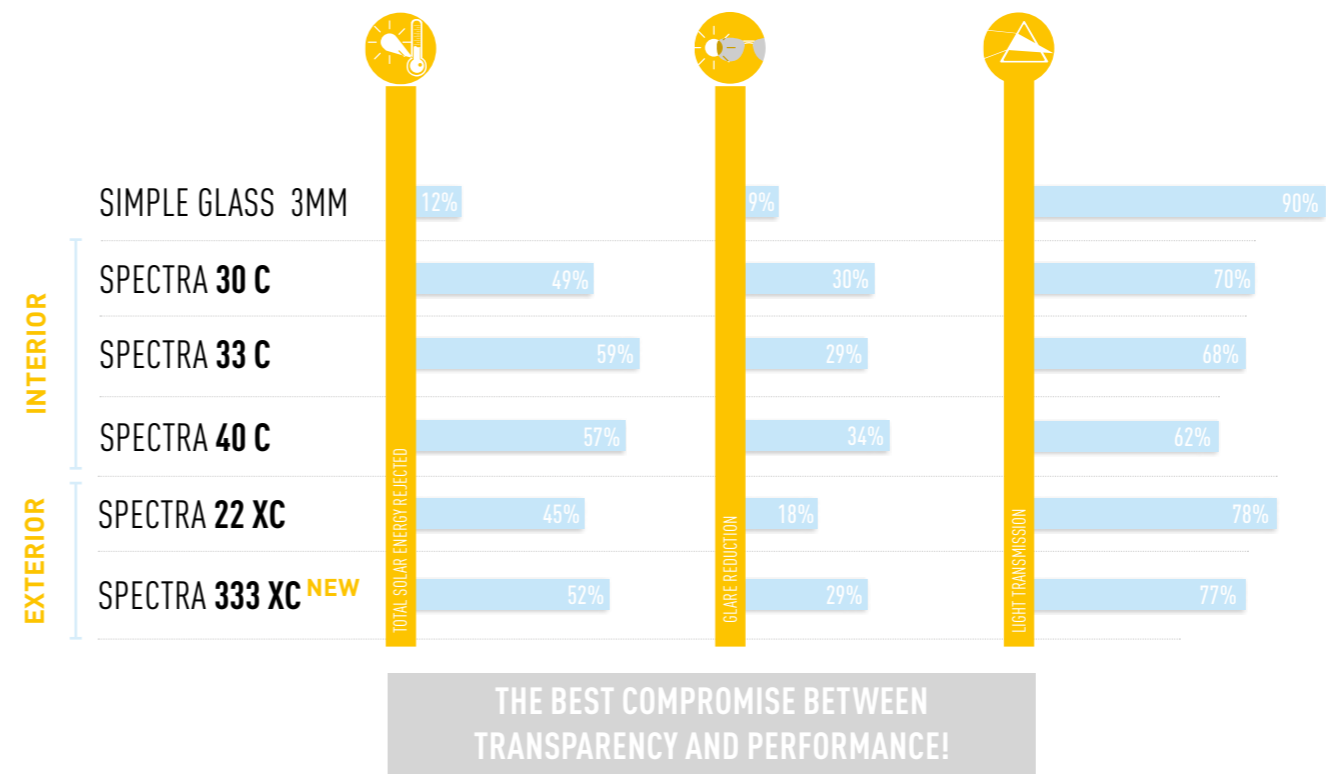

- > Up to 10 years warranty with the ultimate evolution of the range, the Spectra 333XC
- > Reduces the greenhouse effect and therefore the heat inside the building.
- > Preserves transparency towards the interior
- > Preserves a neutral facade (type Spectra 30 C or 22 XC)
- > Rejects up to 95% of the rays infrared (Spectra 333 XC)



DID YOU KNOW?

WHAT IS VISUAL ACUITY ?

Visual acuity is the ability to discern information brought to the brain by sight. It determines the quality of vision.

In the case of our films, it is the ability of the eye to adapt to the perceived brightness in the room when this is diminished. The **perceived transmission of visible light** is therefore **adapted** and therefore higher.

In short, below **80%** tint, the eye will correct the before/after film so well that we will not feel the effect of the tint, which is the case for the entire Spectra range.

SPECTRA 333 XC



Grand Commun Chateau de Versailles - Versailles - France



WARM COLOR AND ANTI-HEAT

THE MULTIGLASS 66 C

Its unique blend of metal alloys makes this film usable on a large part of windows without risk of thermal shock. It is also for you the alternative to films in the "Silver" range, allowing you to enjoy the look of the film in addition to performance.

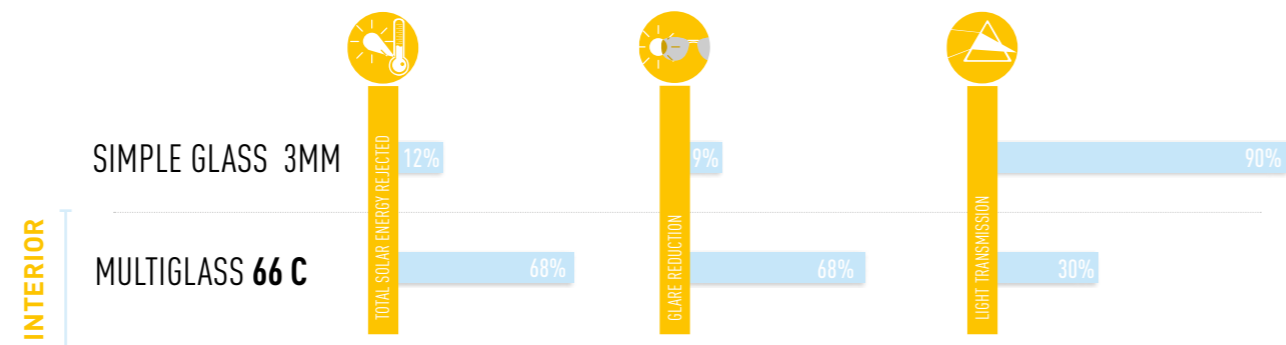

THE NATURAL RANGE

This "neutral" solar protection of appearance makes it possible to preserve the current aesthetic of your buildings, with however a solar yield lower than the classic series "Silver".

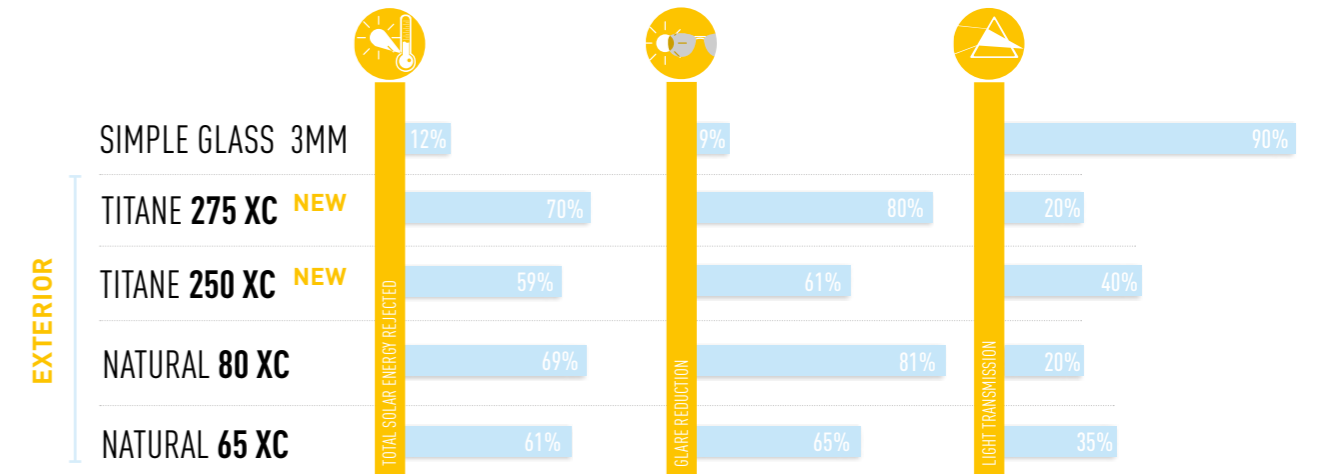

NATURAL EFFECT PRESERVING YOUR FACADES

Throughout the year, **temperature issues** are present.

In winter, cold windows and walls are unpleasant and in summer the heat passes through the windows.

To combat these issues, our **Solar range** is effective throughout the year.

NEED SERENITY THROUGHOUT THE YEAR?

SOLUTIONS

THE SOLAR RANGE

This film is applied on the inner face of a glazing to form a reflective screen that returns solar energy.

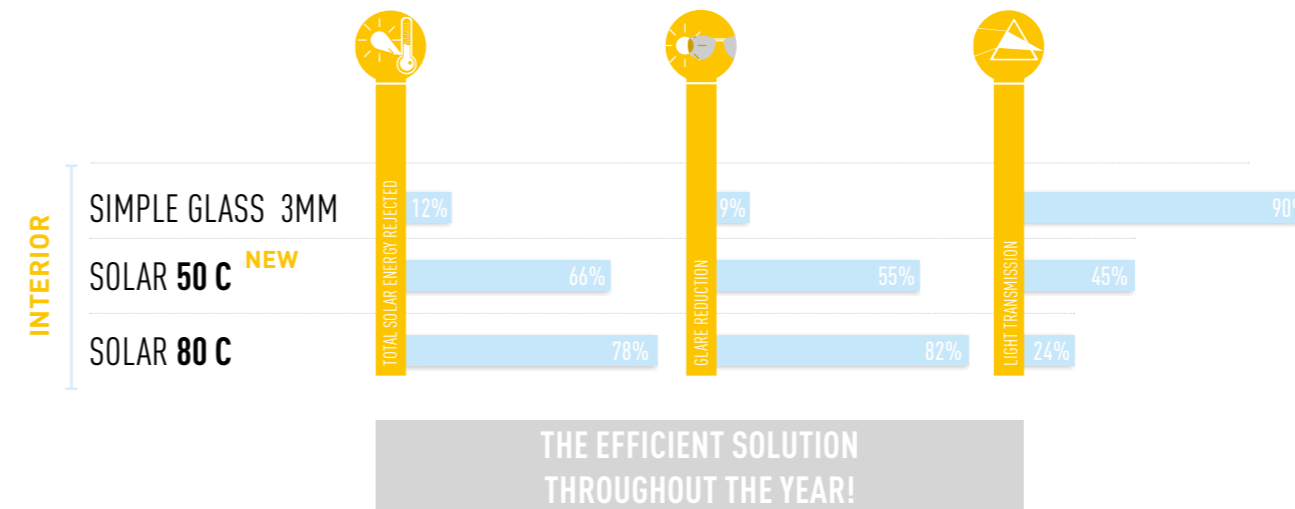

- > THE 4-season solution
- > Insulates in winter to keep the heat inside.
- > Reduces the greenhouse effect in summer
- > Extreme performance (Solar 80 C) up to the right compromise (Solar 50 C)

DID YOU KNOW?

HOW THE SOLAR RANGE FILMS WORK

Thanks to its reverse composition compared to conventional solar films, the Solar range allows heat to be reflected inwards.

The film makes it possible to achieve a 33% (Solar 80 C type) reduction in heat loss in winter, which reduces heating costs and considerably increases interior comfort with a temperature gain of up to +4°C observed.

In the summer, it acts as a solar film by preventing some of the sun's energy from entering, thus reducing the heat.

FILM COMPOSITION

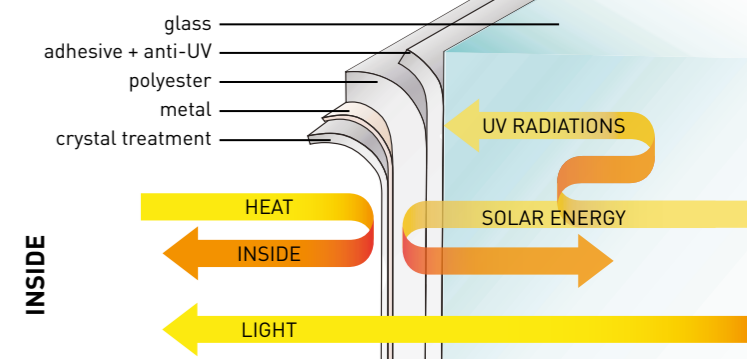

The issue of intimacy is important at work and in certain areas of daily life.

The need to see without being seen finds its solution through our **Vista range** and allows you to create a space of intimacy thanks to its two-way mirror aspect.

PRIVACY ISSUE?

SOLUTIONS

THE VISTA RANGE

This film is applied on the inner face of single or old types of glazing (> 20 years old) or outside for any other kind of glazing forming a reflective screen that controls solar energy, as well as prying eyes from outside.

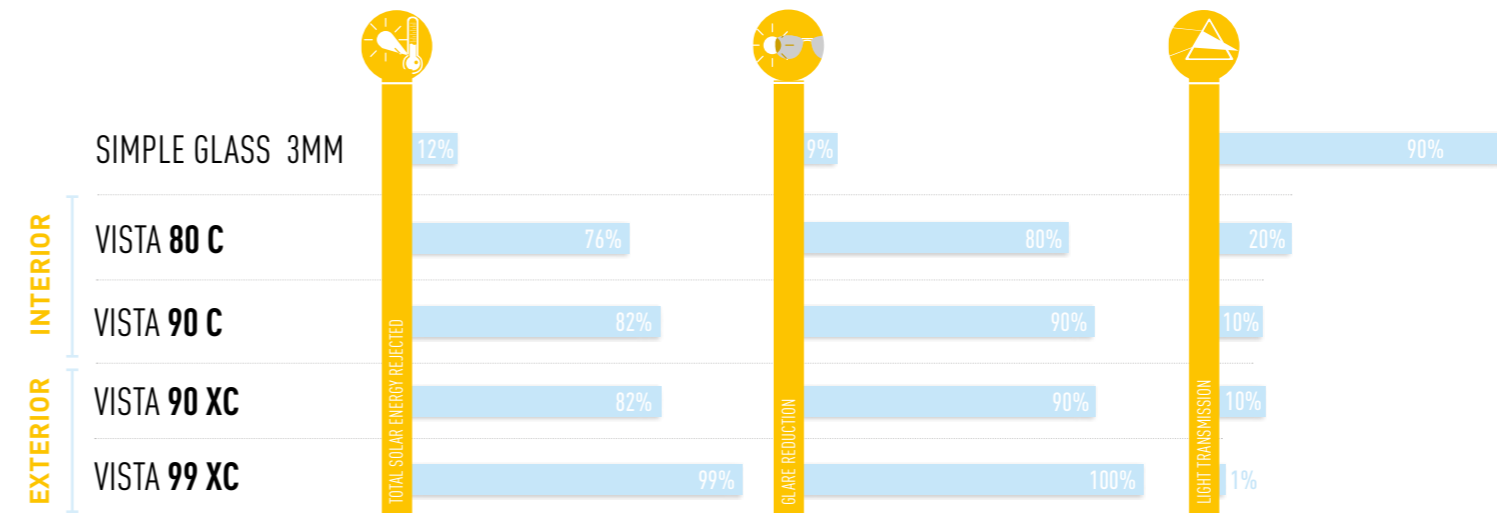

THE BEST PERFORMANCE IN ALL ASPECTS!

- > Allows you to see outwards without being seen inwards
- > No more risk of glare
- > Reinforces your glazing in case of burglary



DID YOU KNOW?

VISTA 99 XC A SOLAR SCREEN EXCLUSIVITY

The Vista 99 XC film is defined by its ability to suppress almost all solar **heat and glare** while still being able to see outwards.

Its **one-way mirror** appearance eliminates any discomfort from opposite sides and provides total visual protection during the day and almost total protection at night.

This outdoor application film has the advantage of being able to **be installed on any type of glass** without any risk of thermal shock.



There is no way to absolutely protect the objects from **discoloration**, unless you put them in the dark out of direct light, at low temperature and keep them out of the air and aggressive atmosphere.

The most efficient solution consists in eliminating UV-A, which is the main cause of damage. They are at + 99% absorbed by using **Clear 1 UVC** or **Neutral 40 UVC** film.

For shops, the new **Total UV 400** will offer the best protection, as it absorbs +99.99% of the length up to 400nm, so even beyond UVA therefore



CLEAR 1 UVC



NEUTRAL 40 UVC

SOLUTIONS

THE ANTI-UV RANGE

This film is applied on the inner face of a glazing to form a reflective screen that filters UV rays while preserving transparency.

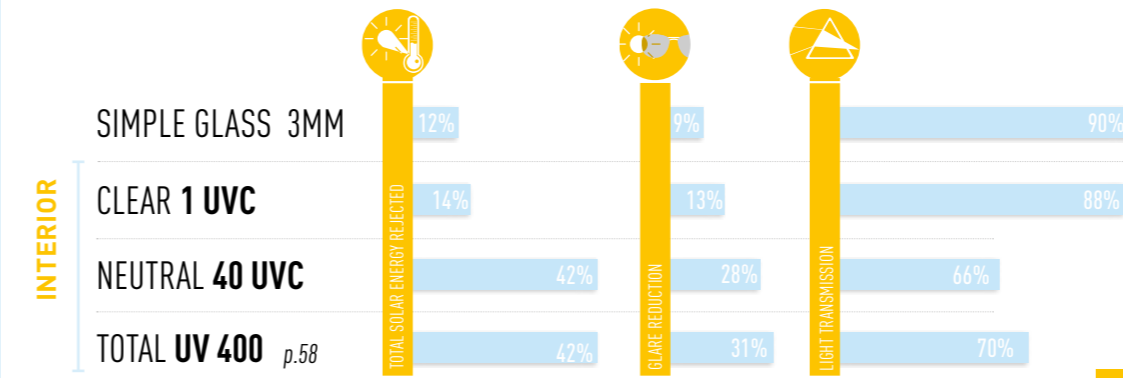

PRESERVE COLORS BY EFFICIENTLY AVOIDING UV

ABSORBS
+99,5%
UV*
*against 40-60% for glasses



- > Reduces discoloration
- > Absorbs radiation beyond 400nm, for total protection (Total UV400)
- > Virtually transparent, it does not alter the appearance of the glass and allows an inward view
- > Invisible from the inside



CLIENT TESTIMONIAL

CSC Window Films is extremely pleased with the product Clear 1 UVC. Our work involves protecting valuable treasure, paintings and furnishings within The National Trust, The National Trust for Scotland, English Heritage, Stately Homes and the Historic House Association. Most of our properties are monitored by Curators and Archivists and the UV is regularly checked to ensure the UV is not at a damaging level. We also work to the National Trust Code of Practice for collection conservation in situ, which determines the amount of light allowed into a Heritage property. The film is nice to work with on top of being optically clear – We would not buy any other product on the market but CLEAR 1 UVC from Solar Screen.

Jed SOUTHGATE
CSC Window Films & Blinds LTD - Royaume-Uni



CLEAR 1 UVC

Musée Van Gogh - Amsterdam - Pays Bas

DISCOLORATION ISSUE



HOW DOES IT WORK?

Our security films form a barrier on the glass to prevent glass splinters from being thrown or scattered inwards when the glass breaks.

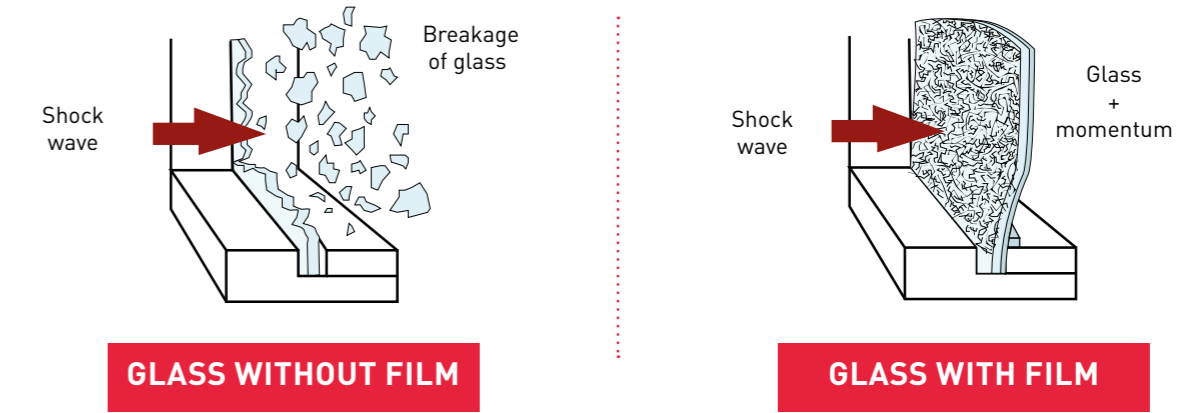

4 CRITERIAS FOR SECURITY FILMS:

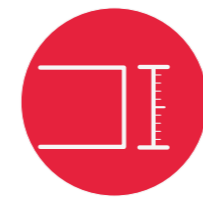

FILM THICKNESS

The higher it is, the greater the resistance of the safety film.



CERTIFICATION

It determines how strong the films remain effective and under which types of impact.

→ EN 12600, EN 356 OU ISO 16933

CF : Did you know? Page 25



TENSILE STRENGTH

It determines the puncture resistance of a film against an impact, expressed here in kg/cm².

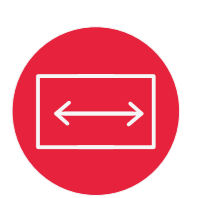

ELONGATION AT BREAK

It is the ability of the film to absorb/absorb a shock, like a net, in order to keep the glass in one piece.



SOLUTIONS

CLASSICAL SECURITY

THE SUPER CLEAR 4C

This film is applied on the inner face of any type of glazing to reinforce the glass and to protect against any falls or splinters of glass breakage.

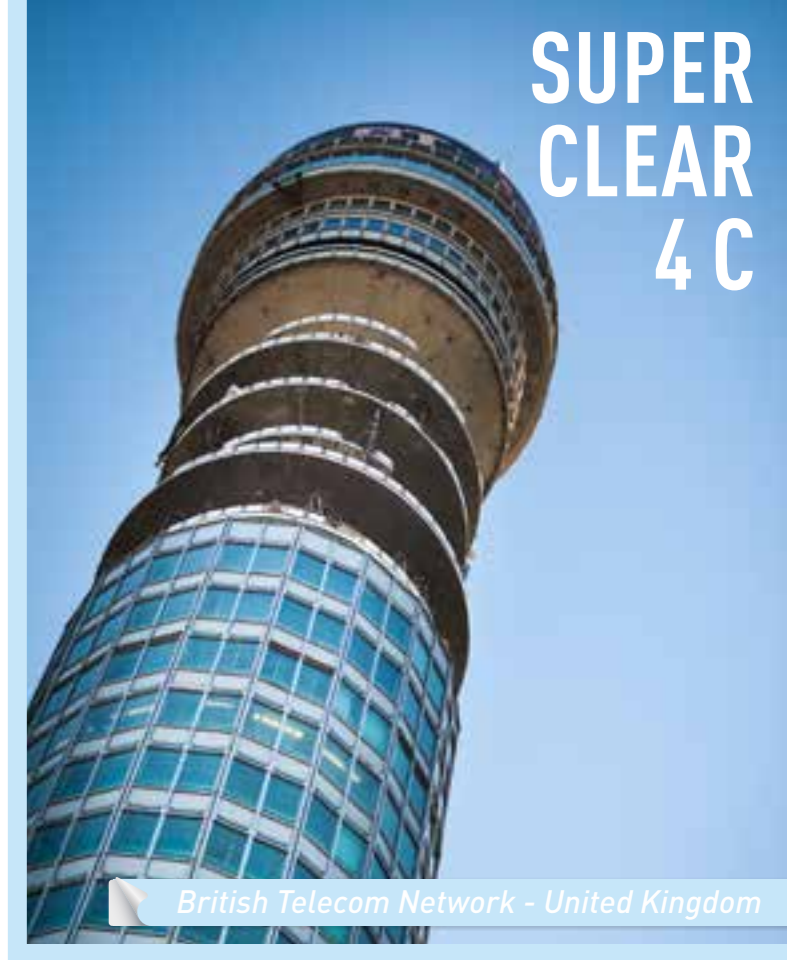
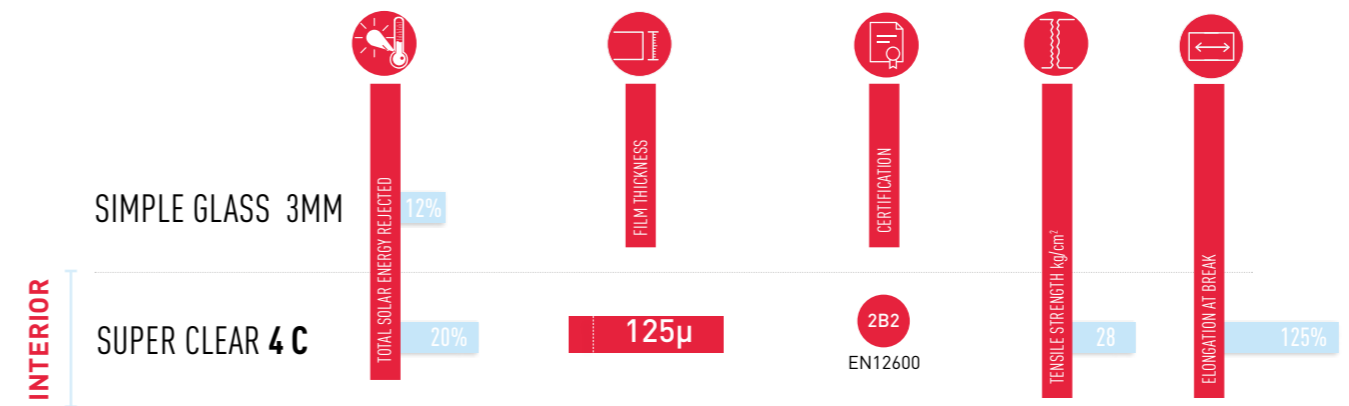

SUPER CLEAR 4C

British Telecom Network - United Kingdom



DID YOU KNOW?

ALL OUR SAFETY FILMS ARE COMPLIANT WITH THE PPMS DECREE

A special personal safety plan (PPMS) is the best response to deal with the seriousness of a major accident situation and to limit the consequences while waiting for the arrival of the emergency services.

Our films help to delay the **break-in**, keep people **safe inside** and avoid glass breakage or projection.





REINFORCED SAFETY

SOLUTIONS

THE SUPER CLEAR 7 AND 8 C

This film is applied on the inner face of any type of glazing to reinforce the glass and to protect against any falls or splinters of glass breakage.

GLASS	FILM THICKNESS	CERTIFICATION	TENSILE STRENGTH kg/cm ²	ELONGATION AT BREAK
INTERIOR SUPER CLEAR 7 C	210μ	1B1 EN12600	34	125%
CLEAR 8 C	240μ	1B1 EN12600	40	125%



DISCOVER

our installation video on our **YouTube** channel!
 > Solar Screen International



DID YOU KNOW?

Glass projectiles thrown at more than 40km/h can cause fatal injuries.

We offer effective prevention solutions to prevent your glass from becoming a potential hazard.

SUPER CLEAR 7 C



CONGRESS CENTRE - GENEVA - SWITZERLAND



THE CLEAR 12 AND 18 C ET 30 C

This film is applied on the inner face of any type of glazing for an extreme strengthening of the window and to protect against any falls or splinters of glass breakage due to an explosion for example.

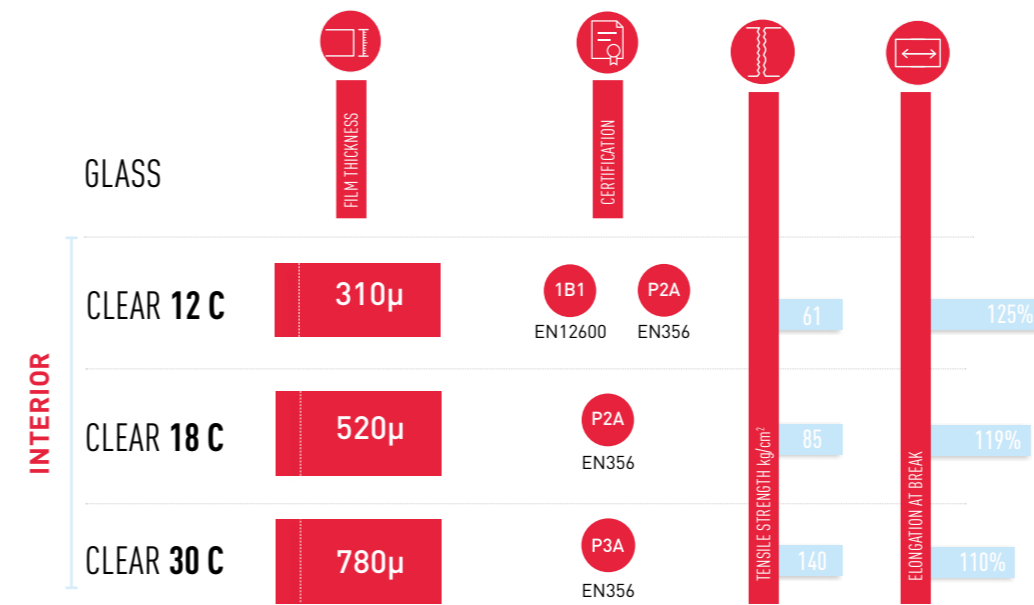

SUMMARY OF THE CLEAR RANGE (4, 7, 8, 12, 18 C & 30C)

- > Greatly reduces possible break-in
- > Protects and secures the occupants
- > Invisible films
- > Limit glass breakage during violent explosions
- > Available in 183cm width reducing the connections of large glazings



DID YOU KNOW?

The type and thickness of the glazing is decisive for the choice of the safety film:

- For glazing at an individual's home, school or town hall, choose **Clear 4 C**.
- For a store or showcase, it is better to choose **the Clear 7 et 8 C range**.
- For any building requiring high security such as banks or state buildings, we strongly recommend the **Clear 12 C ou 18 C range**.
- Finally, for all reinforced protections, the new **Clear 30 C** will be your best ally! It transforms a 4mm single glazing, equivalent 44.3, (9mm) or a high performance laminated glass, classified P3A!



SOLAR PROTECTION AND SAFETY

THE SILVER RANGE

This film is applied on the inner face of any type of glazing to reinforce the glass and to protect against any falls or splinters of glass breakage. Its hue, depending on its degree of transparency, also reduces heat and glare.

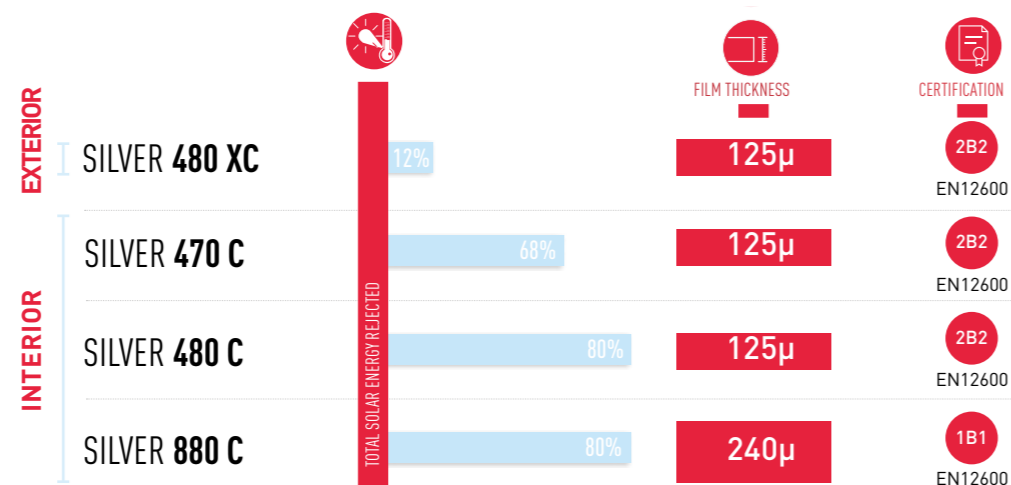

THE SECUR

This film is directly applied on the mirror to reinforce it and protect against any falls or splinters of glass breakage. The film is fully transparent and does not alter the appearance and properties of the mirror.

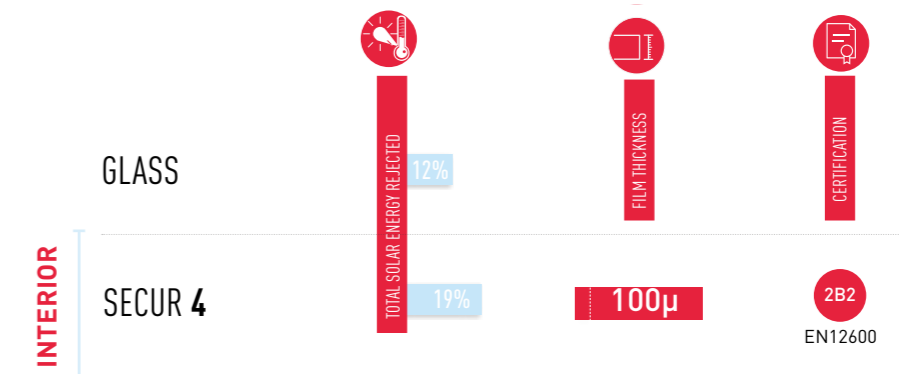

In France, the ERP regulation (decree of 25/06/1980) article X9 requires the safety of mirrors in sports halls.



MIRROR BACK PROTECTION



ANTI-GRAFFITI

PROTECTION 24/24

This transparent film is applied to your windows to protect them from possible vandalism attempts such as graffiti or scratches. Just remove the film after degradation to find a window as new.

Both the Protec 4C and the Safe 4XC are classified according to EN45545-2, a strict railway standard, and come out with the best HL3 classification.

	GLASS	PROTEC 4 C	PROTEC 6 C	SAFE 4 XC	CLEAR 4 XCG
INTERIOR	12%	19%	20%	19%	17%
		120μ	185μ	120μ	125μ
EXTERIOR		HL3	HL3	HL3	2B2
		EN45545-2	EN45545-2	EN45545-2	EN12600



TEST INISMA

Our films meet the European standards EN356 and EN12600, as shown in the pictures here.



This basic certification provides effective protection against shocks and bumps. It guarantees that the glazing remains in one piece.



This superior type certification offers true resistance to any type of impact. A highly dissuasive solution against break-ins and damage.



This premium certification offers resistance to the blast of an explosion and makes it possible to secure buildings requiring this high level of security.



WHY INSTALL FILM ON YOUR AUTO WINDOWS?

The films of the Automotive range are mainly used according to your desires and the appearance you want to give to your vehicle. They also offer intrusion protection and avoid heat and UV to enter the vehicle. The ideal solution to protect your children and beautify your vehicle.

3 CRITERIAS FOR THE AUTOMOTIVE FILMS:



TOTAL SOLAR ENERGY REJECTED

The higher it is, the lower the total heat and keeps freshness in the vehicle interior.

ALL FILMS PROTECT FROM UV

REDUCTION IN SOLAR GLARE

The higher the number, the better the visibility in the vehicle interior.

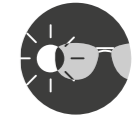

TRANSMISSION OF THE VISIBLE LIGHT

The higher the number, the higher the loss of brightness.

→ The visual acuity need to be taken into account.

CF : Did you know? Page 11

CAR BODY PROTECTION

SECURITY ANTI-CARJAKING





THE BEST FOR YOUR VEHICLE

SOLUTIONS

THE BELUGA RANGE

An original tinted glass will have as specific property only its tint and will thus simply allow to limit the opposite in the passenger compartment.

A window tinted with our Beluga films not only regulates the interior facing but also limits the entry of heat and strengthens your windows to reduce the possibility of carjacking, all with 99% of UV absorbed.



THE NANO-CERAMIC CONSTRUCTION ALLOWS A REAL EFFICIENCY COMPARED TO THE ORIGINAL LENSES SIMPLY TINTED!

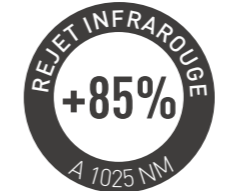

- CLEAR GLASS 3MM
- TINTED GLASS 3MM
- BELUGA 250C
- BELUGA 265C
- BELUGA 275C
- BELUGA 285C
- BELUGA 295C

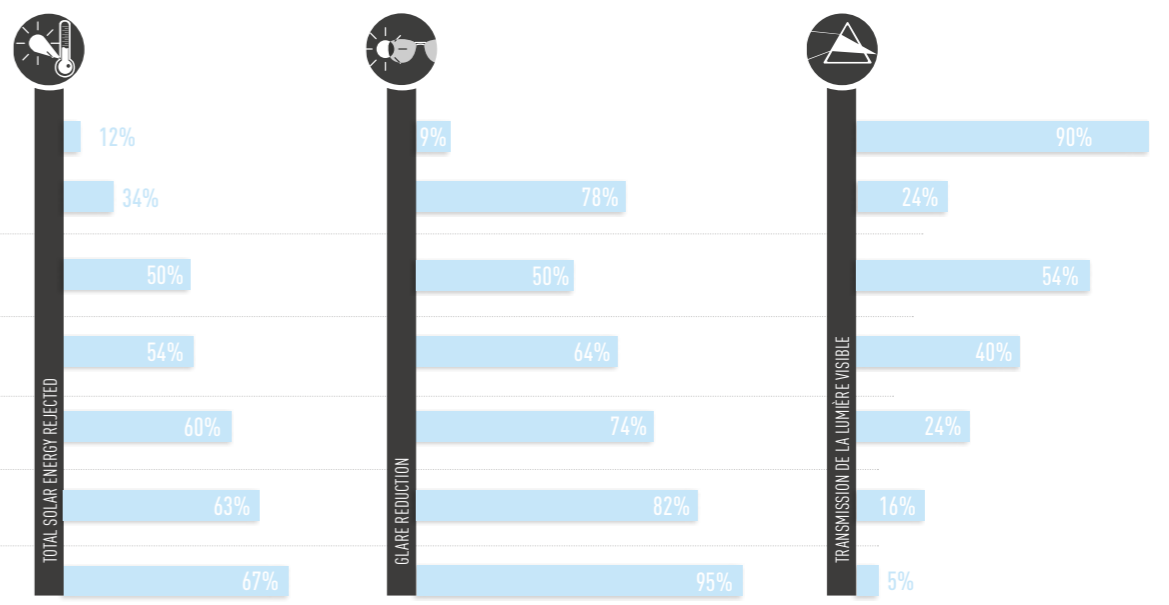

DISCOVER
our installation
video
on our **YouTube**
channel!
> Solar Screen
International





FAVORITE FILM

SOLUTIONS

THE PANTHERA RANGE

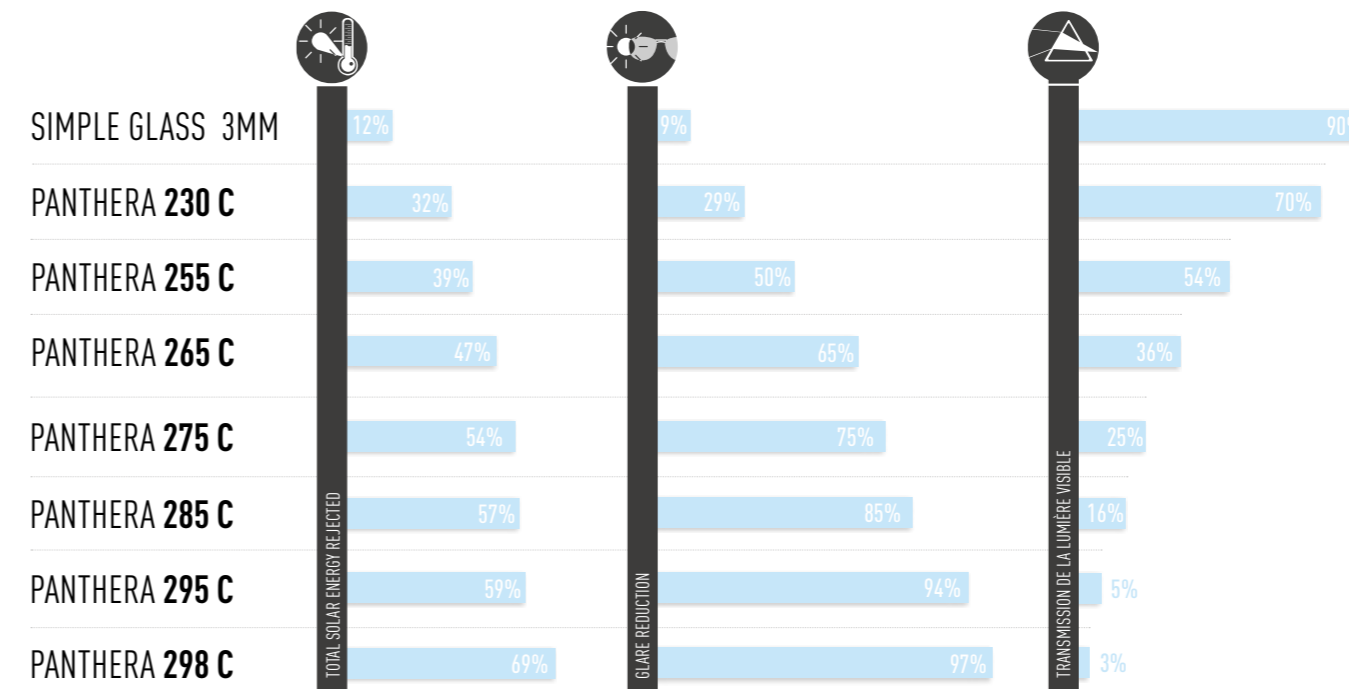

DÉCOUVREZ

notre vidéo de pose Panthera sur notre chaîne **YouTube** !
 > Solar Screen International



DID YOU KNOW?

WHAT IS THE DIFFERENCE BETWEEN AN ORIGINAL **TINTED GLASS** AND A **TINTED GLASS WITH OUR AUTOMOTIVE FILMS**?

An original **tinted glass** will have as specific property as its hue and will therefore limit the opposite

A tinted glass with our Automotive Solar Screen films not only regulates the internal opposite but also limit the input of heat and strengthen your windows to reduce the possibility of carjacking, all with 99% UV absorbed.





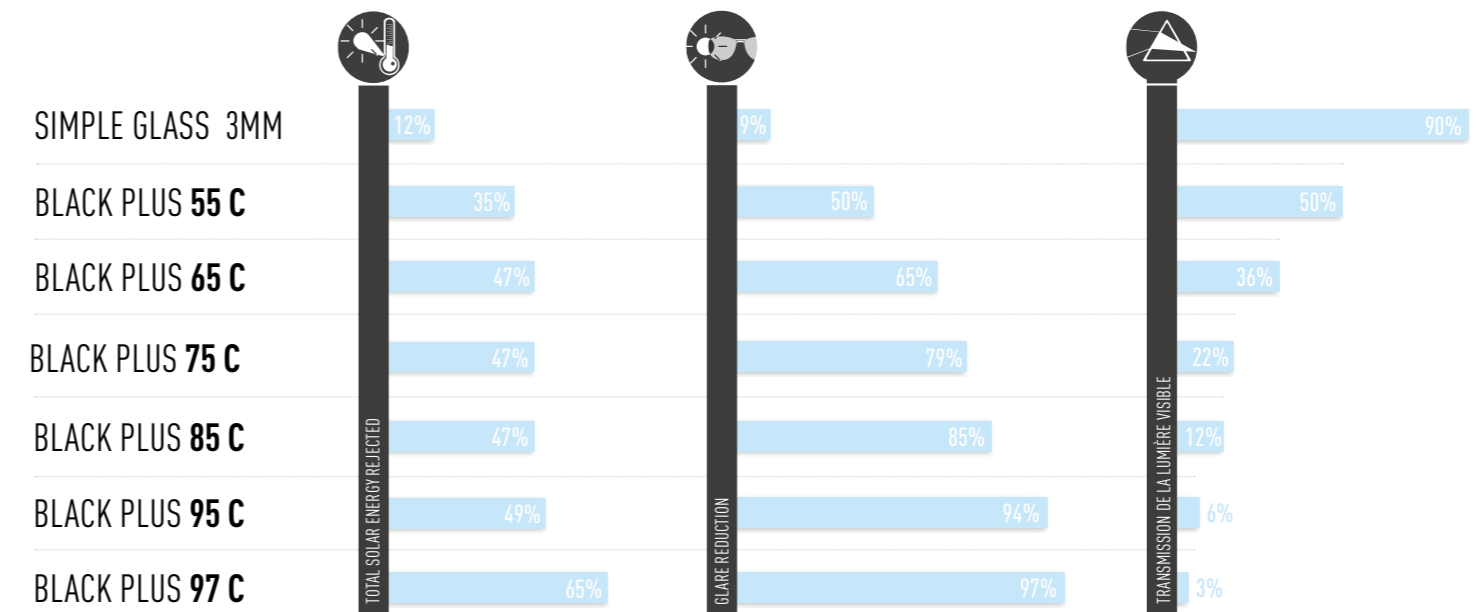

NANOTECHNOLOGY FILM: AESTHETIC AND COMFORT

THE BLACK PLUS RANGE



DISCOVER
 our installation video
 on our **YouTube** channel!
 > Solar Screen International



DID YOU KNOW?

HOW TO CHOOSE YOUR AUTOMOTIVE FILM?

The visual characteristics are divided into 2 main criterias:

COLOUR : all colours are possible to match the windows to the colour of the car body. The most popular and appreciated solar film is the film from light gray to deep black.

OPACITY : several levels are available: gray is the most transparent, it looks like the classic option of tinted windows offered by car manufacturers, while

deep black prevents any vision from outside to the inside of the vehicle.

The opacity of an Automotive solar film is measured in percentage of transmission of the external light approximately of 30 to 35% for the "clear" films, 20 to 25% for the "average" films, 10 to 15% for the "dark" and less than 5% for "black" films.



NO INTERFERENCES

THE CHARCOAL RANGE

The unmetallized premium film is applied on the inner face of the car's glazing, allowing you to tint your windows by limiting interference problems.



CLIENT TESTIMONIAL

I've been using solar film for more than 20 years now and I have to say that I am amazed by the quality of the Cendre series. The last two years we've used the Solar Screens Charcoal, and I can only say that it's even better. It's high quality, the colour is a nice deep black, it's super easy to install, and best of all - something we really appreciate - it runs beautifully on the Dot Matrix. At Lund Solfilm we're very pleased and so are our customers.

Daniel LUND
LUND SOLFILM Director - Denmark

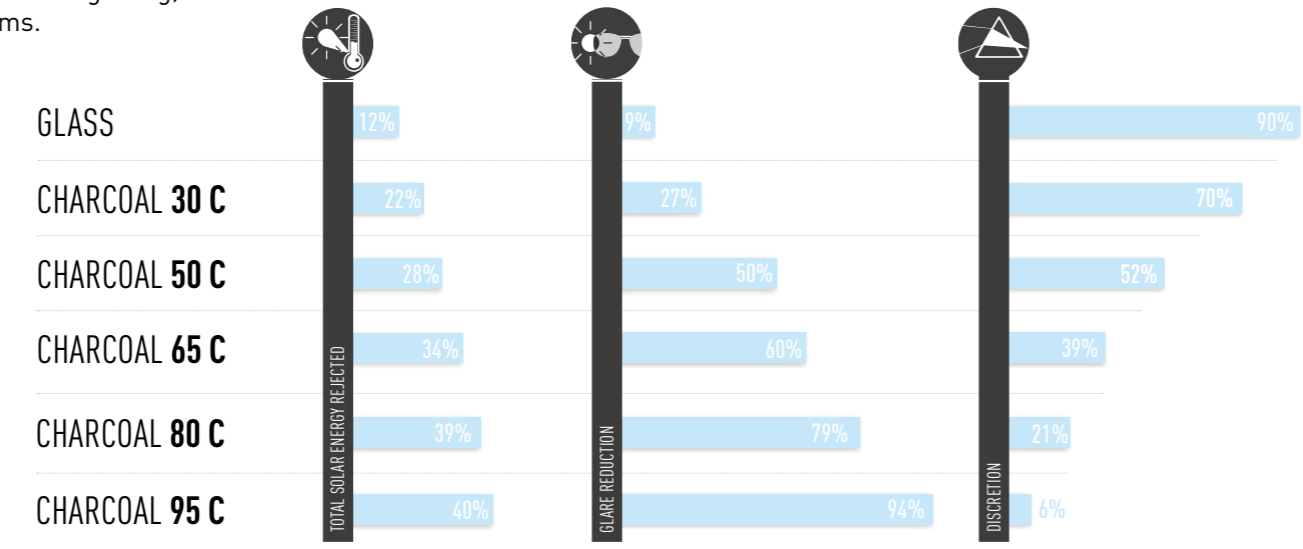

THE OMEGA AND SPECTRA RANGES

Reinforce the safety of your windows in addition to aesthetic and solar performance.

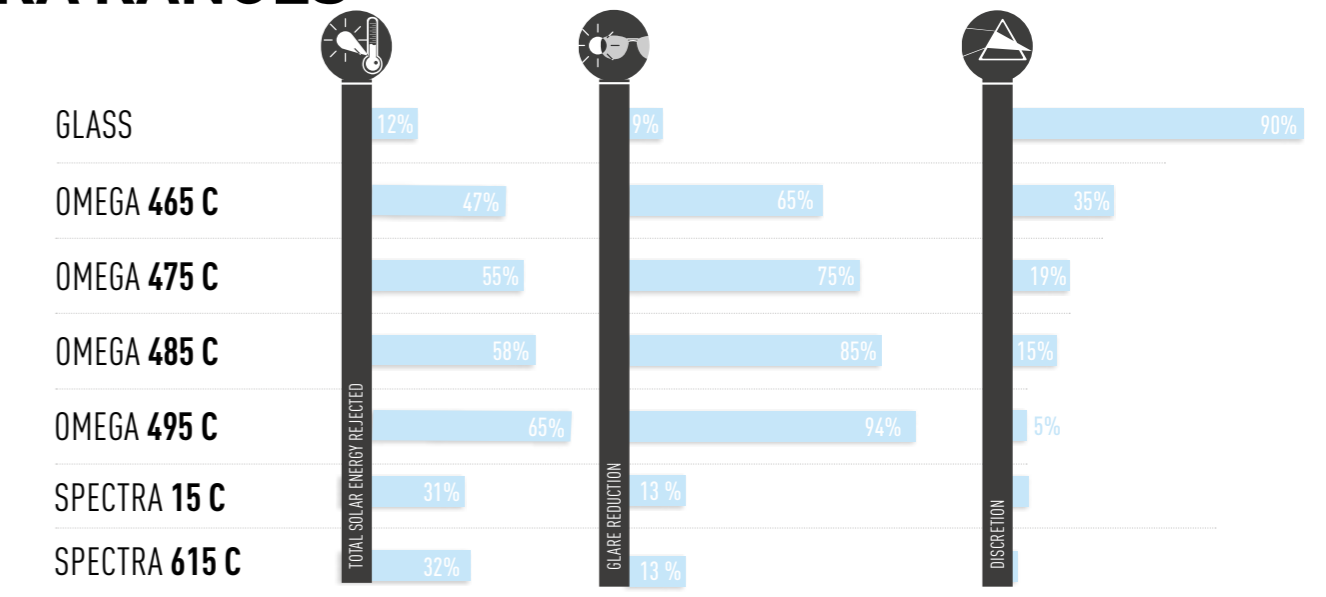

ULTIMATE PROTECTION

THE PROTECTOR ULTRA RANGE

The Protector Ultra Top film is the flagship product for all fans who want to protect their beautiful car bodies from the everyday hazards.

Thanks to its flexible polyurethane and its thickness, this film will dampen and protect from shocks and impacts, **until it self-heals in case of slight scratches.**

The Protector Ultra film, by its quality, offers your car an invisible shield.



IMPRIMABLE

ULTRA CLEAR

CLEAR PRINT PET

Technology: PET
Thickness: 50 µm

CLEAR PRINT PET EASYSTICK

Technology: PET
Thickness: 140 µm

CLEAR PRINT PVC

Technology: Polymer PVC
Thickness: 80 µm

OPALESCENT

MAT ACID

Technology: Polymeric PVC
Thickness: 80 µm

MAT ACID BUBBLE FREE

Technology: Polymeric PVC
Thickness: 80 µm

MAT ACID X

Technology: CAST PVC
Thickness: 75 µm

MAT ACID GRIS

Technology: Monomeric PVC
Thickness: 75 µm

ICC Profiles available

MICRO-PERFORÉ

ULTIMA 30

Technology: Polymeric PVC
Thickness: 140 µm

ULTIMA 40

Technology: Monomeric PVC
Thickness: 140 µm

COVER STYL'

J3

Technology: PVC Polymeric Calendered
Thickness: 225 µm

J14

Technology: PVC Polymeric Calendered
Thickness: 220 µm

J15

Technology: PET
Thickness: 220 µm

ICC Profiles available

WHITE

WHITE PRINT PVC

Technology: Monomeric PVC
Thickness: 100 µm

ICC Profiles available

HOW TO USE IT?

The printable and cuttable film is more than ever considered as a media support for the future.

Both ephemeral and affordable, it is a communication support which makes it possible to bring your ideas to life, your decorative desires and all your advertising campaigns.

It is the solution, to whatever size window or support, on which you can deliver a message.

It should be known that the window, for example, remains one of the best way to generate traffic to a point of sale or to attract curiosity for the launch of a new product.

Our printable films can also be used simply for the embellishment and personalization of office spaces, or any other place that has glazed spaces.



3 TYPES OF PRINTING FOR PRINTABLE FILMS:



SOLVENT & ECO SOLVENT



UV



LATEX



THE TRANSPARENT RANGE

THE CLEAR PRINT PET, EASYSTICK AND CLEAR PRINT PVC

Clear Print PET is the optical film par excellence. Transparent, based on high quality polyester, it is by definition the film for UV printing machines. It also absorbs more than 95% of ultraviolet rays and protects you from glass splinters and cuts in case of glass breakage (2B2 certification according to EN 12600). **Clear Print PET Easystick** is the latest generation media support that accepts all types of printing. Its silicone adhesive simplifies both application and removal.

Clear Print PVC is the transparent film that can be used on any type of machine. Its polymer PVC base offers the best possible transparent result for a PVC base.



THE MAT FILMS

Our Mat based polyester range is summarized in 4 advantages:

- Printable on any type of machine
- Easy installation
- Perfectly opalescent while letting some of the light through
- Comforting and preventing glass splinters in the event of impact
(2B2 certification according to EN 12600)

3 FLAGSHIP PRODUCTS AVAILABLE

Mat WHITE	Mat ACID-X	Mat ACID-GREY
--------------	---------------	------------------



THE TRANSPARENT RANGE



THE MICRO-PERFORATED RANGE

THE ULTIMA PRINTABLE FILM FOR SHOWCASE AND TRANSPORT

The micro-perforated adhesive is a support for applications on all types of windows and showcases.

Thanks to its structure, this film hides the interior of your shop, car ... while leaving an excellent visibility from the inside to the outside. It is designed to withstand climatic hazards (resistance to rain, strong heat ...).

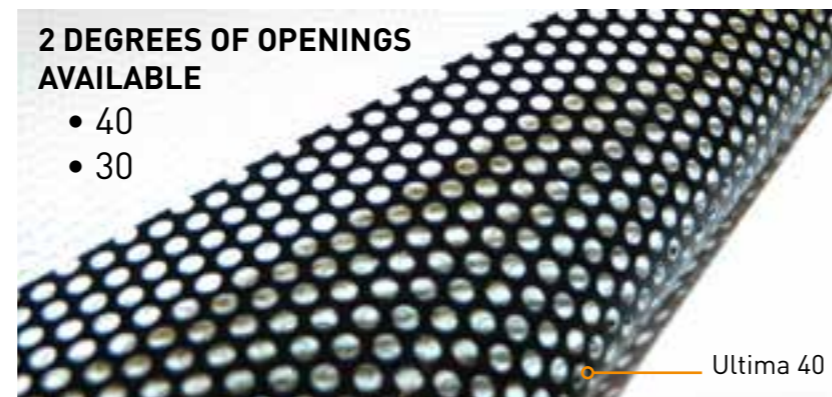

2 DEGREES OF OPENINGS AVAILABLE

- 40
- 30

Ultima 40

THE COVER STYL' J3 AND WHITE PRINT PVC

Our **J3** comes from our **range of adhesive** wall and furniture coverings. It is a PVC calendered film, which is also printable on any type of machine. So far, nothing spectacular, except to offer a film 4 times thicker than a classic PVC, with an extra structure, allowing you to offer a hyper durable and resistant performance. In case of large surfaces, the J14 will hide the usually visible joints, thanks to its wooden structure.

Our **White Print PVC** is the solution in **glossy white for glass**. Usable on any type of machine, its monomeric PVC base offers the best possible result for a white PVC base and its bubble free adhesive facilitates installation.

COVER STYL' J3 SATIN MAT

WHITE PRINT BRILLIANT PVC



THE WHITE RANGE



THE OPALESCENTS RANGE



THE FROSTED RANGE



THE WHITE RANGE



CLIENT TESTIMONIAL

Solar Screen products provide complete satisfaction to our customers since 1989!

The technical, practical and innovative aspects of Solar Screen are a real asset. Their strength of proposal with their ability to bring new products each year allow to meet the varied and multiple needs of our market.

Their support is a high professional quality and allows us to develop with serenity.

Being a partner is the best definition of Solar Screen corporate identity.

*Willy Jouie
Filmatec - Blinds and films for windows*

Discover more designs on our website : solarscreen.eu

THE BLACKOUT RANGE

Two products for total privacy.

The blackout films are completely opaque, they do not let light to enhance or prying eyes.

2 COLOURS AVAILABLE :

OPAQUE NACRE

OPAQUE NOIR

THE COLOUR RANGE



DICHROIC FILM



+ de 20 coloris à retrouver sur : solarscreen.eu



FIND

all our references
in our Design brochure



**IT'S
SCIENCE!**
Ask for your new brochure.
Find all the films
that make up the Advanced range.

E FILM
CONTROL OPACITY

Have control over the transparency of
your windows thanks to this film that
becomes opaque under a weak current
3 colors available



DATA JAMMER

Data protection! This film allows the view, except for your screens on which data is displayed.



DISCOVER
the technical data sheet and the
installation guide in our special
flyer!



PROJECTION FILM

Thanks to this film, transform your windows into a display
screen for all your projections.
The image will be clear, sharp and visible on both sides.

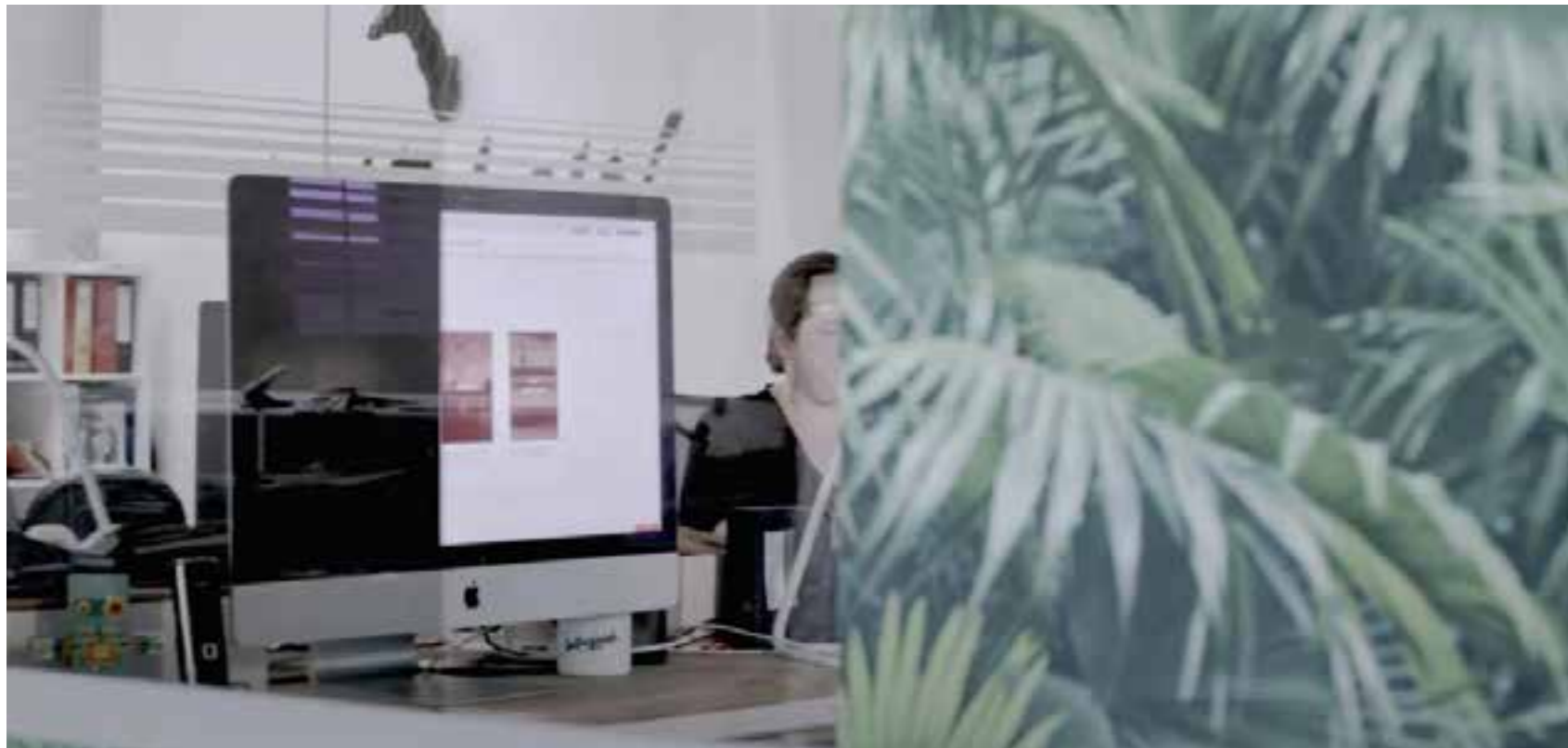
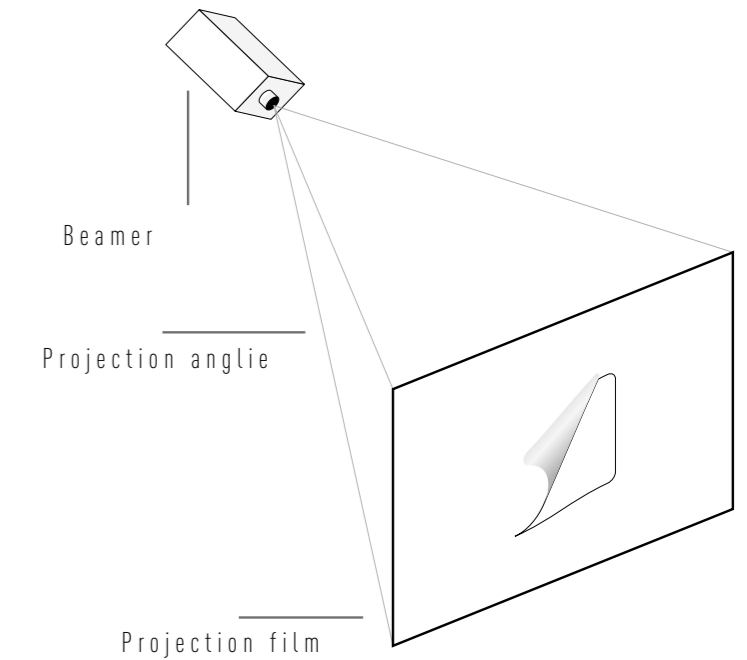

OFFICE UPGRADE

THE RANGE OF ERASABLE PAINTINGS

WHITEBOARD



Erasable board! Innovative! Unstructured permanent adhesive for installation on glass panes

MAGNETIC WHITEBOARD



Turn your surfaces into an erasable board with a ferrous layer for your magnets as a bonus!

CLEARBOARD



Now use your windows as a notepad for your meetings and other silly thoughts! Plus it's green!

ADVANCED SUN PROTECTION

CLARITY 245 XC



The future in the present! Thanks to the progress made in the industry, most modern buildings benefit from efficient glazing in winter, and just about in summer! Here, the Clarity 245XC will give you the additional efficiency you need for real comfort in the summer, without losing any light. Great!

ECLIPSE 40C-80C PHOTOCHROMIC ^{NEW}

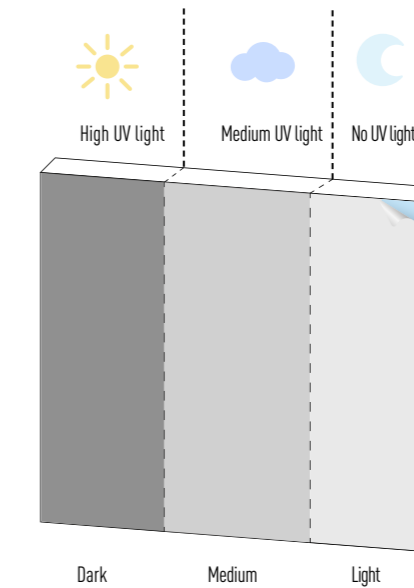

Ultimate evolution in the field! Sun protection that tints to the sun!

SPECTRA 333 XC ^{NEW}



The best film in the world? It has it all: an invisible appearance and a titanic infrared rejection! All from one of the best factories in the world, guaranteeing quality, as evidenced by its 10-year warranty, with no additional peripheral sealing or interference on the frequencies of your mobile devices.

ADVANCED ANTI-UV

TOTAL UV 400



Super UV protection, with +99.99% of all UV (A, B and C) absorbed.

AMBRE C

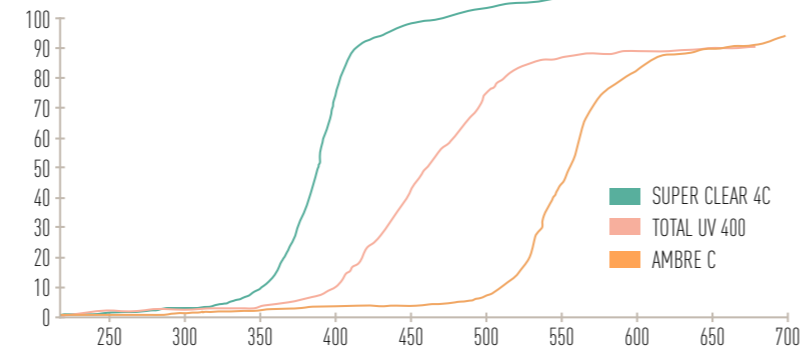

Orange colored film, which absorbs the wavelength beyond UV, super anti-UV, whose use is to protect photosensitive surfaces (inactinic film).
Use in laboratory or welding workshop, because of its color, in multilayer which allows to protect the eyes from welding arcs.

ADVANCED PROTECTION

VISTA 99XC



Thanks to its high density of metal, the Vista 99XC, mirror of the exterior, black of the interior, makes it possible to see without being seen, almost day and night.

MIRROR BACKING



Adhesive power out of the ordinary!
To secure your cracked glass while waiting for their replacement.

ANTIFOG



Protects your glass surfaces from fogging up, whether it's a store, refrigerated fridge, or swimming pool and other verandas/winter garden where humidity is high.

THE ANTI HIGH FREQUENCY RANGE

Thanks to its alloy of nickel and silver or copper, these films allow an electromagnetic wave protection of almost 30dB to 37dB of attenuation on the high frequencies, while being slightly tinted.

NS 50 DB29



CU 20 DB36



NS 50 dB29

CU 20 dB36

dB	5	10	15	20	21	22	23	24	25	26	27	28	29	30	35	36	40	50	60	70
TRANSMISSION	31,6%	10%	3,13%	1%	0,78%	0,63%	0,50%	0,39%	0,31%	0,25%	0,20%	0,18%	0,12%	0,10%	0,03%	0,02%	0,01%	0,001%	0,0001%	0,00001%

THE DESIGN OF YOUR OFFICE

MIROIR TOTAL



Super UV protection, with +99.99% of all UV (A, B and C) absorbed.

DICHROIC FILMS



AURORA SUMMER



AURORA WINTER

These dichroic films give a unique and modern look to your windows and other surfaces, between warm colours (Aurora Summer) and cold colours (Aurora Winter).



In France, at the Emerainville site, each store is hand-made, tailor-made according to a recognized and appreciated expertise in order to improve the comfort and well-being of people.



An expertise that lasts for more than 30 years

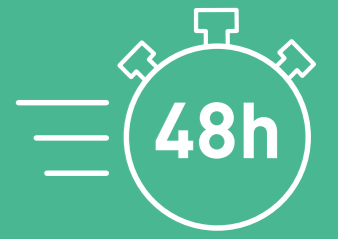

Prototype delivered in 48h



A wide network of suppliers in all of France

Heat problem?



STORE FILM

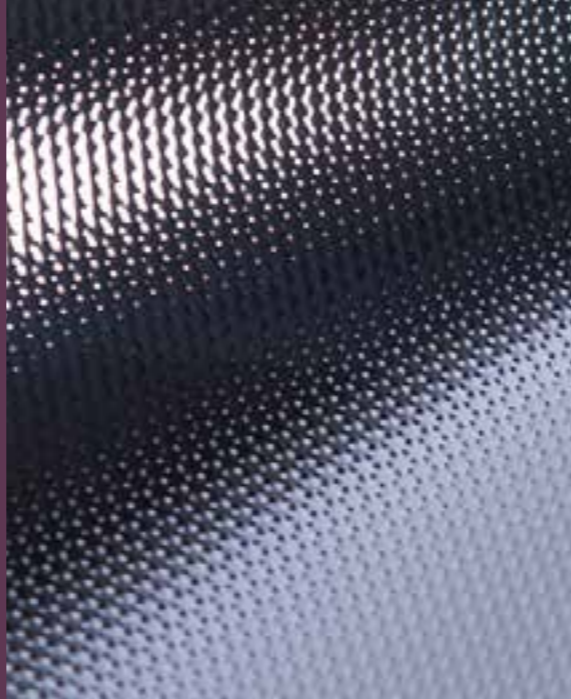

Need a change ?



SCREEN VISION by Mermet

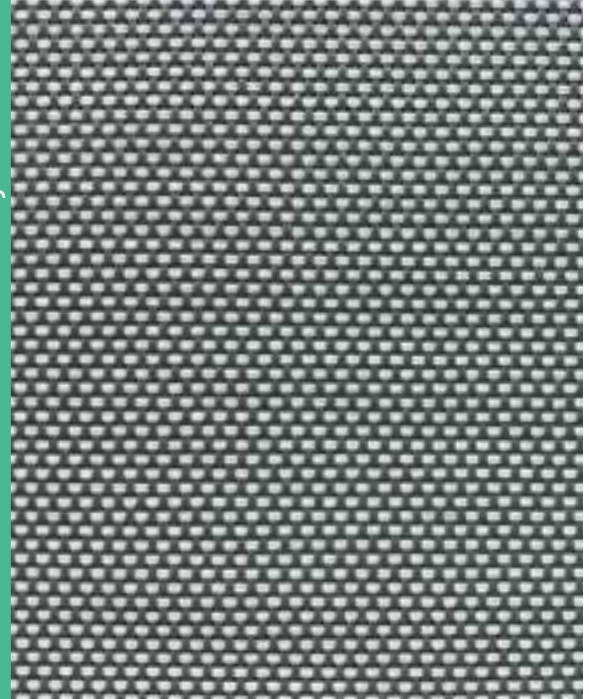

Glare problem?



SOLTIS 99 by Serge Ferrari

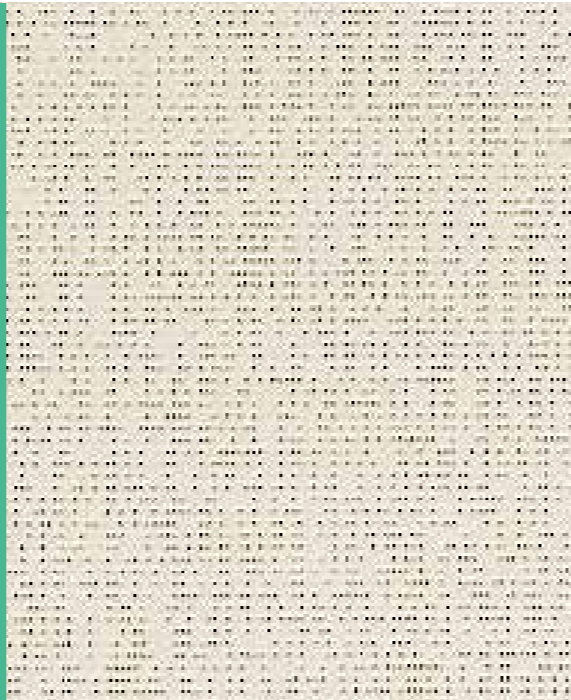

Privacy problem?



ELYSEE

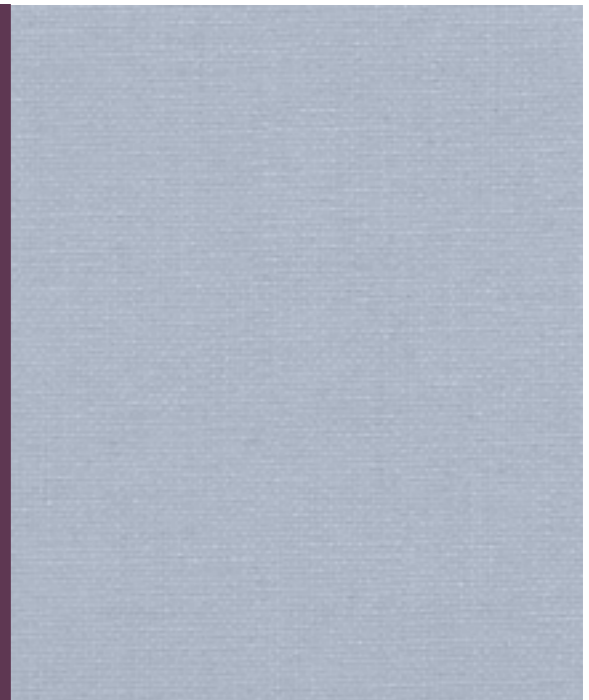

Need design and performance?



DECO SOLAR



Need darkness?



BLACKOUT



Need a cheaper solution?



VÉNITIEN



CLIENTS TESTIMONIALS



From the small site to the bid solicitation, we highlight the detail for the finish. Quality is our daily goal and that's what we offer to our customers with Solar Screen blinds.

We are today a key player in solar protection in our sector and already more than 20,000 Solar Screen blinds serve our customers.

Benoit SCHNEIDER
Priva stores - France
PRIVA STORES



We had a fantastic experience with Soltis blinds for our project at AMAZON in Barcelona. The 800 stores were produced in 3 weeks and we installed 50 stores per person per day. The customer was very satisfied with the result and the effectiveness of the product!

I can only speak positively about the "Soltis" product, its mechanism, the production and the service provided to our company.

Matthias KUNZ
CEO Grupo Prosol - Espagne



DISCOVER

all our references in our brochure :





DISCOVER COVER STYL'
THE INNOVATION OF RENOVATION!



Club Med 

This solution differs from traditional renovation. In a few words, Cover Styl' fully meets our expectations for long-term renovation. We have renovated over 190 rooms in a very short time and we recommend this very innovative solution for its quick application and resistance. It also has a very competitive price that makes it unbeatable!

Denys ROYER - Club Med Consultant

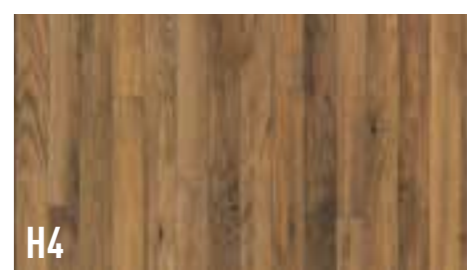



NOVOTEL

During the renovation of our Novotel, we decided to redo our lounge bar and our spa. I've been pleasantly surprised by the reactivity and the advices provided by the Cover Styl' team. The solution and the product itself have incredible potential!

Cover Styl' has saved us a lot of time and money, that's why I strongly recommend using this product especially for hotels, the quality / performance ratio is undeniable.

Dominique GRANDJONC
General Manager Novotel Roissy CDG

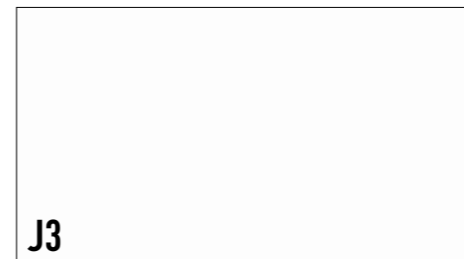
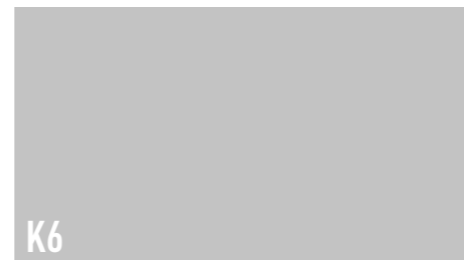
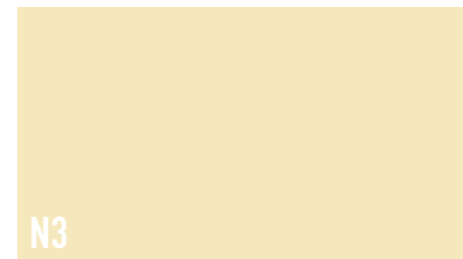

MARBLE

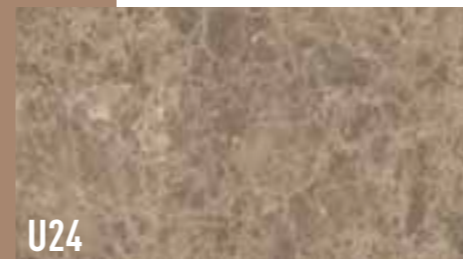
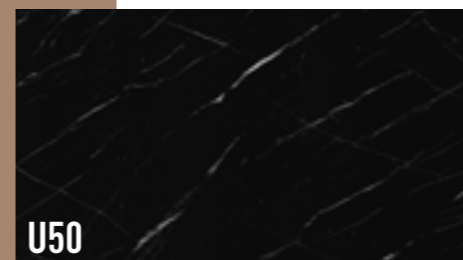

METALLIC

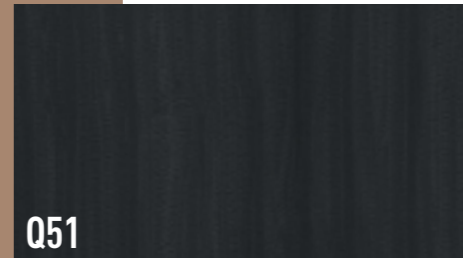

NATURAL STONE

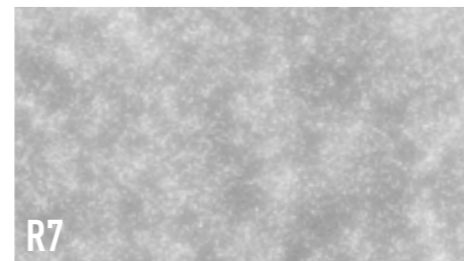
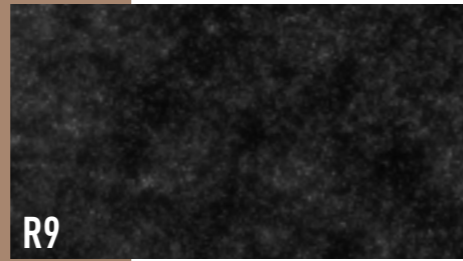

LEATHER



GLITTER

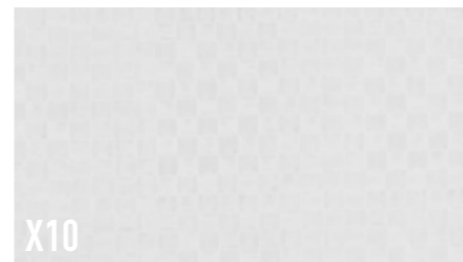
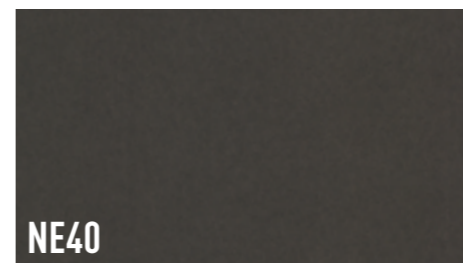
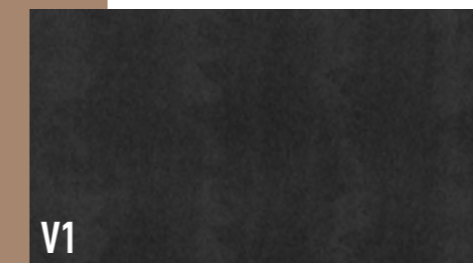
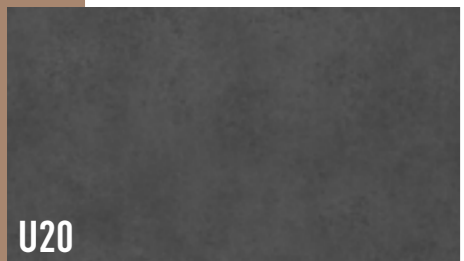

FABRIC



Cover Styl' is an adhesive film that covers most surfaces in no time and at a lower cost.

True-to-life textures



Textured



Fast



Quality



Stretchable



Certified



Customizable



Style



Cost Efficient



Easy



Warranty



Wide-Range



Non-Stop



Hygienic



Limitless



Soothing



Fire rated



As an interior designer in Spain, I find in Cover Styl' an elegant, fast, genuine and economic way to renovate or highlight interiors, offices, wall or furnitures

Their wide pattern selection is a great help to please most of my clients!

María SANTOS ALCALÁ
Interior Designer - Estudio Maria Santos

THEY TALK ABOUT COVER STYL'

195 rooms seemed to be obsolete and Cover Styl' allowed us to put them on the same level without changing all the furniture. They were able to provide a similar wood colour and uniformity of red that we needed.

This choice allowed us to avoid the demolition of existing furniture and to simplify the construction of the work environment in a very short time. The flexibility, speed and cost of Cover Styl' have made it possible to renovate the elements without replacing them.

For this reason, we have also been able to renovate some furniture and elevators that were not originally included in the project.

Marie PROST
Agency Philippe Prost - Architecte

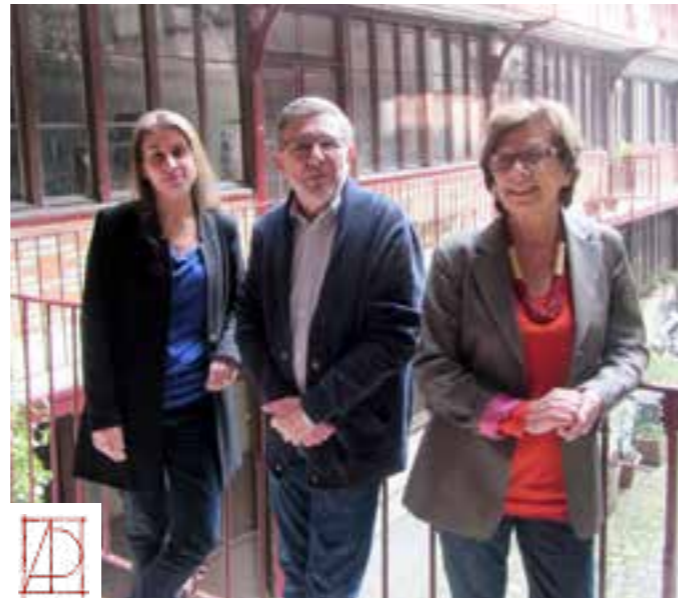

HOTEL



BEFORE



AFTER



WHY REPLACE WHEN YOU CAN UPGRADE?

SUPERMARKETS



RECREATION CENTRES



BEFORE



AFTER

FLORISTS



BEFORE

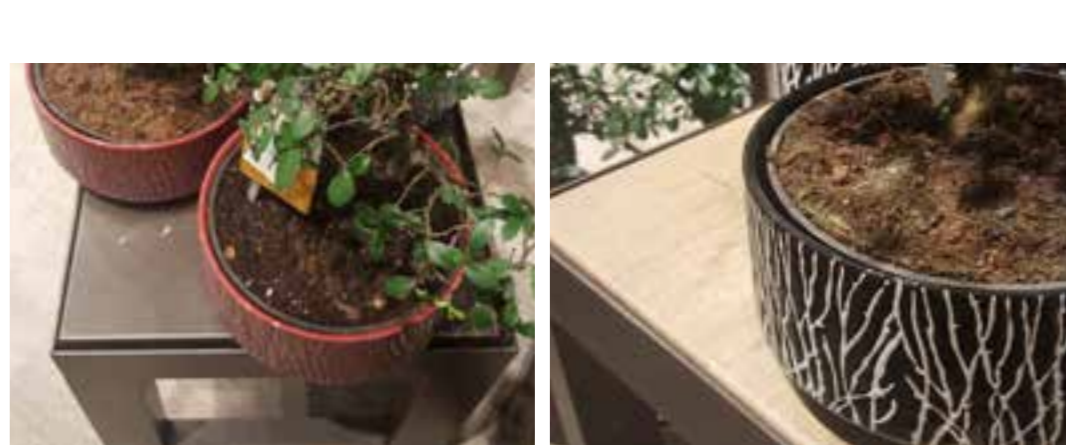

AFTER



SUPERMARKETS



BEFORE



AFTER

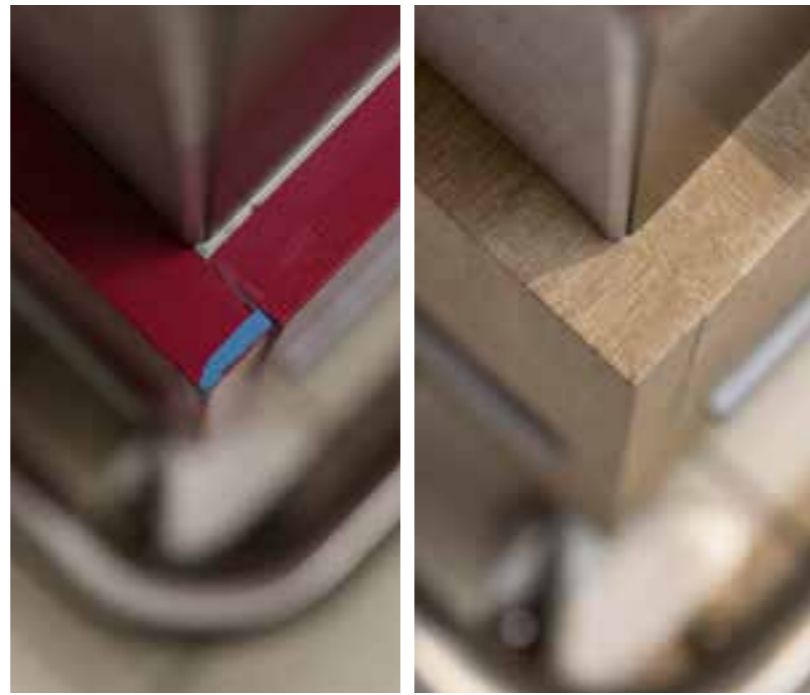

HOTELS



BEFORE



AFTER

(+55 51) 3222 8833 | petersenrepres@petersenrepres.com.br



PETERSEN

Rua Almirante Camara 122
Tristeza/Porto Alegre/RS Cep.91920-450